

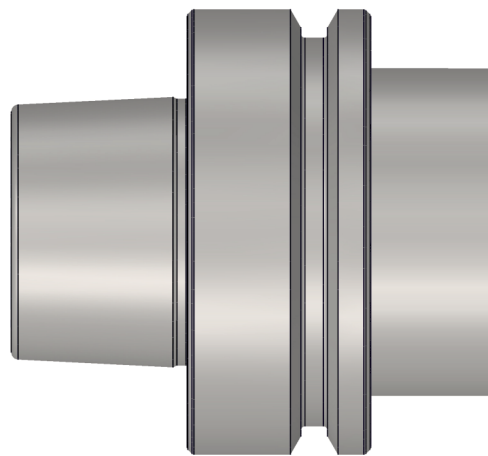

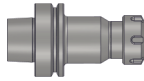





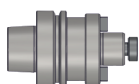

Precision Tool Holders HSK-F (DIN 69893 - 6)

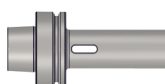

INDEX

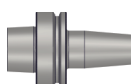
Sr. No.	Contents		Page No.
①	Technical Information: HSK - F (DIN 69893-6)		180
②	Collet Chuck ER (DIN 6499)		181
③	Weldon Type End Mill Holder (WE) (DIN 6359)		182
④	Face Mill Holder (Through Coolant) (FMH-K)(DIN 6357)		183
⑤	Combi Shell Mill Adaptor (CSMA) (DIN 6358)		184
⑥	Morse Taper Adaptor (MTA) (DIN 6383)		185
⑦	Boring Bar Blank		186
⑧	Master Mandrell		187
⑨	Milling Cutter Arbor (MCA)		188
⑩	Shrink Fit Holder 4.5 Degree (SFH 4.5°)		189
⑪	Quick Change Tapping Chuck (KWFLK)		190

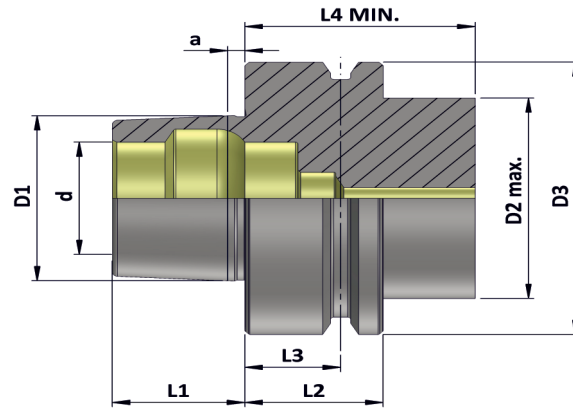

HSK-F	d	D1	D2	D3	a	L1	L2	L3	L4
63	26	38	53	63	5	25	26	18	42

Material :- Case hardened steel, tensile strength in the core min. 950 N/mm²

Execution :- Case hardened to HRC 58 ± 2, Case Depth 0.8 mm., Silver finish.

Accuracy :- Taper Angle Class AT 3

Maximum Run out of the Internal Taper with respect to the External Taper 0.005 mm

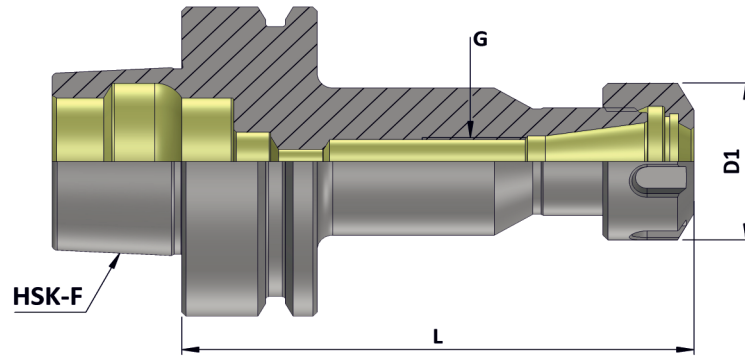

HSK - F (DIN 69893 - 6)
Holders

HSK-F (DIN 69893-6) Collet Chuck (ER)

(Balanced To 2.5 G 25000 RPM)

Item Name	Item Code	HSK-F	Suitable Collet	Collet Capacity	D1	G	L	Nut	Spanner
HSK-63F ER 16 060 2.5G25000 SL	K10260149117227	63	ER 16	0.5-10	32	M10X1	60	UM/ER16	E16
HSK-63F ER 16 100 2.5G25000 SL	K10260149148227	63	ER 16	0.5-10	32	M10X1	100	UM/ER16	E16
HSK-63F ER 16 160 2.5G25000 SL	K10260149175227	63	ER 16	0.5-10	32	M10X1	160	UM/ER16	E16
HSK-63F ER 25 075 2.5G25000 SL	K10260151127227	63	ER 25	1.0-16	42	M18X1	75	UM/ER25	E25
HSK-63F ER 25 100 2.5G25000 SL	K10260151148227	63	ER 25	1.0-16	42	M18X1	100	UM/ER25	E25
HSK-63F ER 25 160 2.5G25000 SL	K10260151175227	63	ER 25	1.0-16	42	M18X1	160	UM/ER25	E25
HSK-63F ER 32 075 2.5G25000 SL	K10260152127227	63	ER 32	2.0-20	50	M22X1.5	75	UM/ER32	E32
HSK-63F ER 32 100 2.5G25000 SL	K10260152148227	63	ER 32	2.0-20	50	M22X1.5	100	UM/ER32	E32
HSK-63F ER 32 160 2.5G25000 SL	K10260152175227	63	ER 32	2.0-20	50	M22X1.5	160	UM/ER32	E32
HSK-63F ER 40 075 2.5G25000 SL	K10260153127227	63	ER 40	3.0-26	63	M30X1.5	75	UM/ER40	E40
HSK-63F ER 40 100 2.5G25000 SL	K10260153148227	63	ER 40	3.0-26	63	M30X1.5	100	UM/ER40	E40
HSK-63F ER 40 160 2.5G25000 SL	K10260153175227	63	ER 40	3.0-26	63	M30X1.5	160	UM/ER40	E40

Accessories:

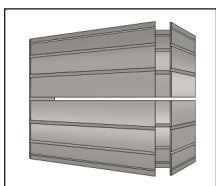

Collet ER (DIN 6499)
Ref. Page No. 233-237

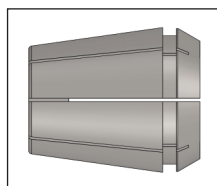

Tap Collet ER-G
Ref. Page No. 238-240

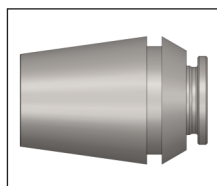

Q.C. Tap Collet (QCTC)
Ref. Page No. 243-251

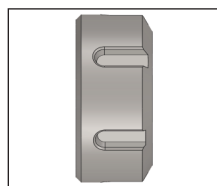

ER Nut & Sealed Nut
Ref. Page No. 220-221 & 224-225

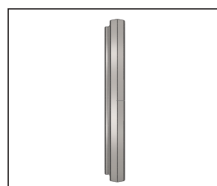

Sealing Disc
Ref. Page No. 226-231

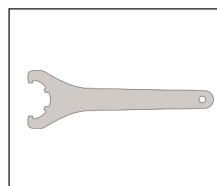

ER Spanner
Ref. Page No. 222

Note: All Dimensions are in mm

Maximum Run out of the Internal Dia with respect to the External Taper 0.005 mm

HSK - F (DIN 69893 - 6)
Holders

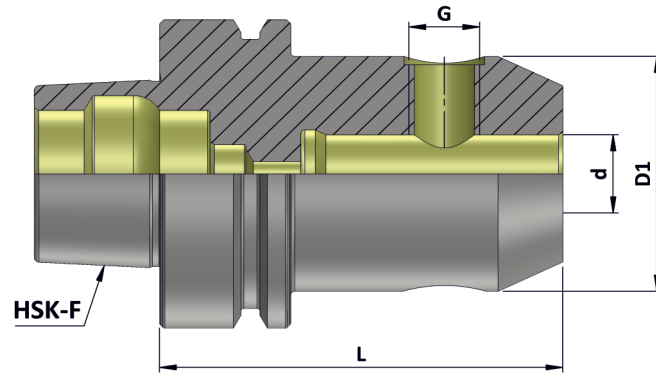

HSK-F (DIN 69893-6) (WE)

(Balanced To 2.5 G 25000 RPM)

Item Name	Item Code	HSK-F	d	D1	G	L
HSK-63F WE06 065 2.5G25000 SL	K10260111123227	63	6	25	M6	65
HSK-63F WE08 065 2.5G25000 SL	K10260112123227	63	8	28	M8	65
HSK-63F WE10 065 2.5G25000 SL	K10260113123227	63	10	35	M10	65
HSK-63F WE12 080 2.5G25000 SL	K10260114131227	63	12	42	M12	80
HSK-63F WE14 080 2.5G25000 SL	K10260258131227	63	14	44	M12	80
HSK-63F WE16 080 2.5G25000 SL	K10260115131227	63	16	48	M14	80
HSK-63F WE18 080 2.5G25000 SL	K10260259131227	63	18	50	M14	80
HSK-63F WE20 080 2.5G25000 SL	K10260116131227	63	20	52	M16	80
HSK-63F WE25 110 2.5G25000 SL	K10260117156227	63	25	65	M18X2	110
HSK-63F WE32 110 2.5G25000 SL	K10260118156227	63	32	72	M20X2	110

Note: • All Dimensions are in mm
 • These Holders are most suitable for Weldon Type End Mill as per standard DIN 1835 - B

Maximum Run out of the External Dia with respect to the External Taper 0.005 mm

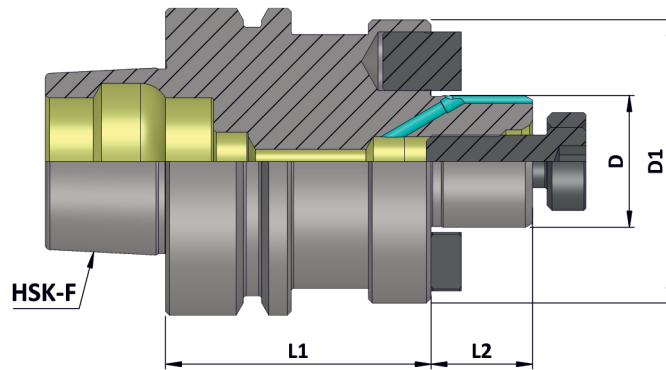

HSK-F (DIN 69893-6) (FMH-K)

(Balanced To 2.5 G 25000 RPM)

Item Name	Item Code	HSK-F	D	D1	L1	L2
HSK-63F FMH-K16 045 2.5G 25000 SL SP.S	K10260131108239	63	16	38	45	17
HSK-63F FMH-K16 100 2.5G 25000 SL SP.S	K10260131148239	63	16	38	100	17
HSK-63F FMH-K22 050 2.5G 25000 SL SP.S	K10260132111239	63	22	48	50	19
HSK-63F FMH-K22 100 2.5G 25000 SL SP.S	K10260132148239	63	22	48	100	19
HSK-63F FMH-K27 055 2.5G 25000 SL SP.S	K10260133115239	63	27	58	55	21
HSK-63F FMH-K27 100 2.5G 25000 SL SP.S	K10260133148239	63	27	58	100	21
HSK-63F FMH-K32 060 2.5G 25000 SL SP.S	K10260134117239	63	32	78	60	24
HSK-63F FMH-K32 100 2.5G 25000 SL SP.S	K10260134148239	63	32	78	100	24
HSK-63F FMH-K40 065 2.5G 25000 SL SP.S	K10260135123239	63	40	88	65	27
HSK-63F FMH-K40 100 2.5G 25000 SL SP.S	K10260135148239	63	40	88	100	27

Note: All Dimensions are in mm

Maximum Run out of the External Dia with respect to the External Taper 0.005 mm

HSK - F (DIN 69893 - 6)
Holders

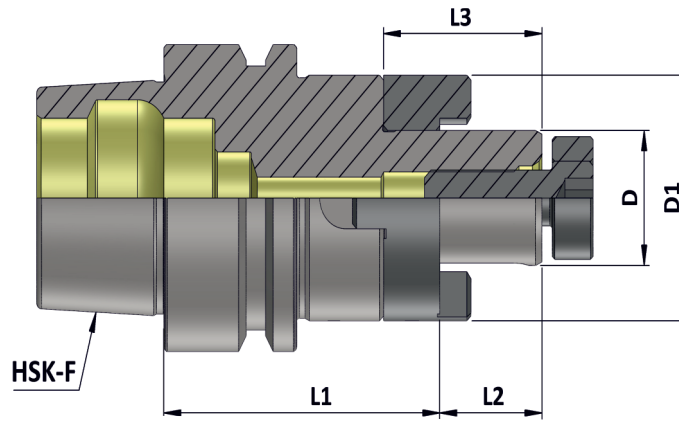

HSK-F (DIN 69893-6) (CSMA)

(Balanced To 2.5 G 25000 RPM)

Item Name	Item Code	HSK-F	D	D1	L1	L2	L3
HSK-63F CSMA16 060 2.5G 25000SL SP.S	K10260121117239	63	16	32	60	17	27
HSK-63F CSMA22 060 2.5G 25000SL SP.S	K10260122117239	63	22	40	60	19	31
HSK-63F CSMA27 060 2.5G 25000SL SP.S	K10260123117239	63	27	48	60	21	33
HSK-63F CSMA32 065 2.5G 25000SL SP.S	K10260124123239	63	32	58	65	24	38
HSK-63F CSMA40 070 2.5G 25000SL SP.S	K10260125125239	63	40	70	70	27	41

Note: All Dimensions are in mm

Maximum Run out of the Internal Taper with respect to the External Taper 0.005 mm

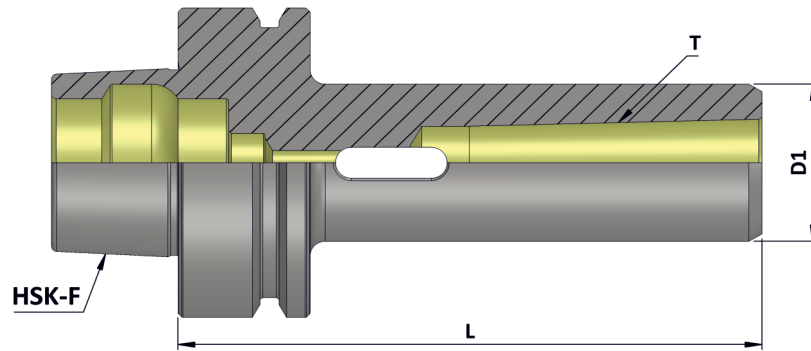

HSK - F (DIN 69893 - 6)
 Holders

HSK-F (DIN 69893-6) (MTA)

(Balanced To 2.5 G 25000 RPM)

Item Name	Item Code	HSK-F	Morse Taper (T)	D1	L
HSK-63F MT01 100 2.5G 25000 SL	K10260447148227	63	1	25	100
HSK-63F MT02 120 2.5G 25000 SL	K10260448162227	63	2	32	120
HSK-63F MT03 140 2.5G 25000 SL	K10260449169227	63	3	40	140
HSK-63F MT04 160 2.5G 25000 SL	K10260451175227	63	4	48	160

Note: All Dimensions are in mm

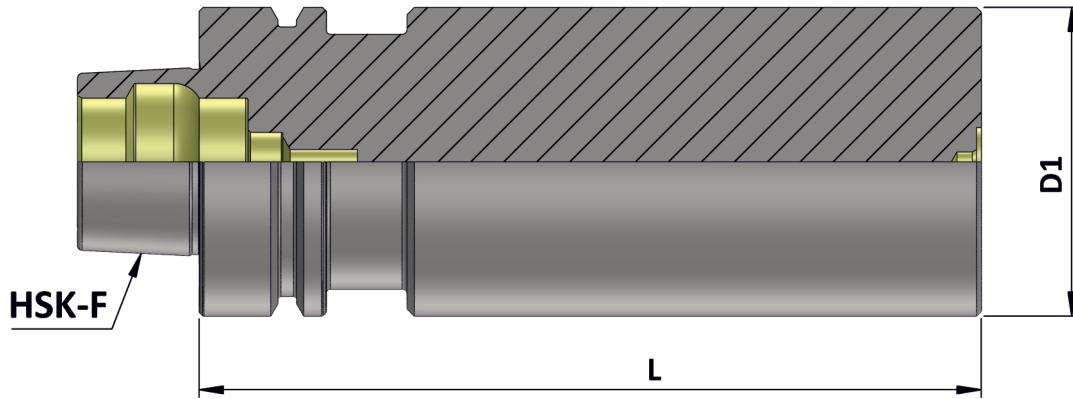

HSK-F (DIN 69893-6) Boring Bar Blank

Item Name	Item Code	HSK-F	D1	L
HSK-63F BORING BAR BLANK DIA 63.0 200	K10260263239227	63	63	200

Note: All Dimensions are in mm

Maximum Run out of the External Dia with respect to the External Taper 0.003 mm

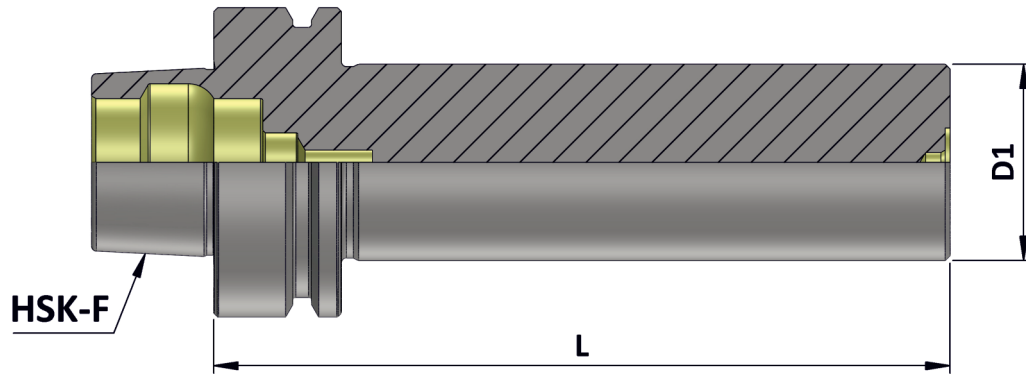

HSK-F (DIN 69893-6) Master Mandrell

(Sub Zero Treated)

Item Name	Item Code	HSK-F	D1	L
HSK-63F MASTER MANDREL DIA40 300	K10260165183227	63	40	300

Note: All Dimensions are in mm

Maximum Run out of the Internal Dia with respect to the External Taper 0.005 mm

HSK - F (DIN 69893 - 6)
Holders

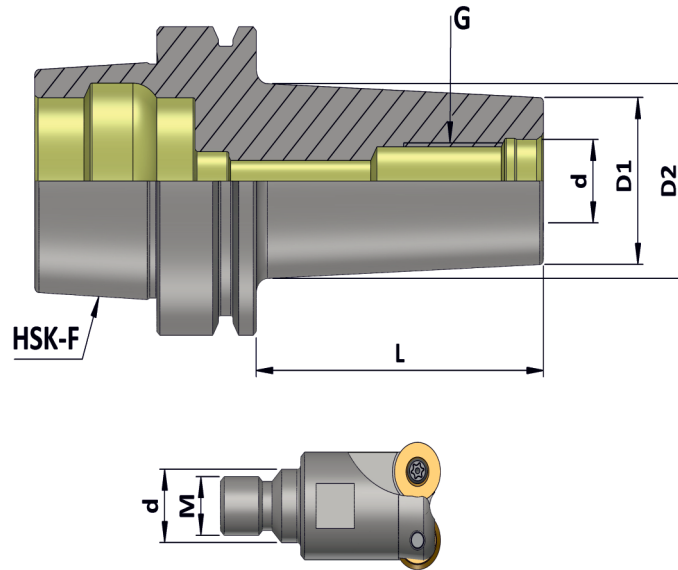

**SCREW-TYPE
 MODULAR MILLING CUTTER**

HSK-F (DIN 69893-6) (MCA)

(Balanced To 2.5 G 25000 RPM)

Item Name	Item Code	HSK-F	d	D1	D2	G	L
HSK-63F MCA06 025 2.5G25000 SL	K10260137101227	63	6.5	10	13	M6	25
HSK-63F MCA06 050 2.5G25000 SL	K10260137111227	63	6.5	10	21	M6	50
HSK-63F MCA08 025 2.5G25000 SL	K10260138101227	63	8.5	13	15	M8	25
HSK-63F MCA08 050 2.5G25000 SL	K10260138111227	63	8.5	13	23	M8	50
HSK-63F MCA10 025 2.5G25000 SL	K10260139101227	63	10.5	18	20	M10	25
HSK-63F MCA10 050 2.5G25000 SL	K10260139111227	63	10.5	18	23	M10	50
HSK-63F MCA12 025 2.5G25000 SL	K10260140101227	63	12.5	21	24	M12	25
HSK-63F MCA12 050 2.5G25000 SL	K10260140111227	63	12.5	21	24	M12	50
HSK-63F MCA12 100 2.5G25000 SL	K10260140148227	63	12.5	21	33	M12	100
HSK-63F MCA12 150 2.5G25000 SL	K10260140173227	63	12.5	21	40	M12	150
HSK-63F MCA16 025 2.5G25000 SL	K10260141101227	63	17	29	29	M16	25
HSK-63F MCA16 050 2.5G25000 SL	K10260141111227	63	17	29	34	M16	50
HSK-63F MCA16 100 2.5G25000 SL	K10260141148227	63	17	29	36	M16	100
HSK-63F MCA16 150 2.5G25000 SL	K10260141173227	63	17	29	42.5	M16	150

Note: All Dimensions are in mm

Maximum Run out of the Internal Dia with respect to the External Taper 0.003 mm

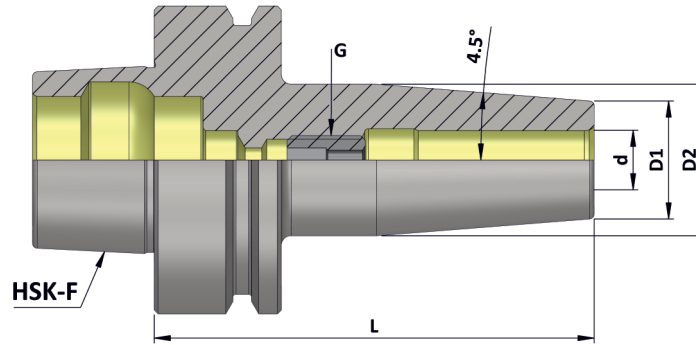

HSK-F (DIN 69893-6) (SFH 4.5°)

(Balanced To 2.5 G 25000 RPM)

Item Name	Item Code	HSK-F	d	D1	D2	G	L
HSK-63F SFH03 080 2.5G 25000 SL	K10260274131227	63	3	10	20	-	80
HSK-63F SFH03 120 2.5G 25000 SL	K10260274162227	63	3	10	20	-	120
HSK-63F SFH04 080 2.5G 25000 SL	K10260275131227	63	4	15	22	-	80
HSK-63F SFH04 120 2.5G 25000 SL	K10260275162227	63	4	15	22	-	120
HSK-63F SFH05 080 2.5G 25000 SL	K10260276131227	63	5	15	22	-	80
HSK-63F SFH05 120 2.5G 25000 SL	K10260276162227	63	5	15	22	-	120
HSK-63F SFH06 080 2.5G 25000 SL	K10260277131227	63	6	21	27	M5	80
HSK-63F SFH06 120 2.5G 25000 SL	K10260277162227	63	6	21	27	M5	120
HSK-63F SFH08 080 2.5G 25000 SL	K10260285131227	63	8	21	27	M6	80
HSK-63F SFH08 120 2.5G 25000 SL	K10260285162227	63	8	21	27	M6	120
HSK-63F SFH10 085 2.5G 25000 SL	K10260279135227	63	10	24	31	M8	85
HSK-63F SFH10 120 2.5G 25000 SL	K10260279162227	63	10	24	31	M8	120
HSK-63F SFH12 090 2.5G 25000 SL	K10260280140227	63	12	24	31	M10	90
HSK-63F SFH12 120 2.5G 25000 SL	K10260280162227	63	12	24	31	M10	120
HSK-63F SFH14 090 2.5G 25000 SL	K10260284140227	63	14	27	34	M10	90
HSK-63F SFH14 120 2.5G 25000 SL	K10260284162227	63	14	27	34	M10	120
HSK-63F SFH16 095 2.5G 25000 SL	K10260281145227	63	16	27	34	M12	95
HSK-63F SFH16 120 2.5G 25000 SL	K10260281162227	63	16	27	34	M12	120
HSK-63F SFH18 095 2.5G 25000 SL	K10260282145227	63	18	33	40	M12	95
HSK-63F SFH18 120 2.5G 25000 SL	K10260282162227	63	18	33	40	M12	120
HSK-63F SFH20 100 2.5G 25000 SL	K10260283148227	63	20	33	40	M16	100
HSK-63F SFH20 120 2.5G 25000 SL	K10260283162227	63	20	33	40	M16	120
HSK-63F SFH25 120 2.5G 25000 SL	K10260287162227	63	25	44	53	M16	120
HSK-63F SFH32 120 2.5G 25000 SL	K10260288162227	63	32	44	53	M16	120

Note: All Dimensions are in mm

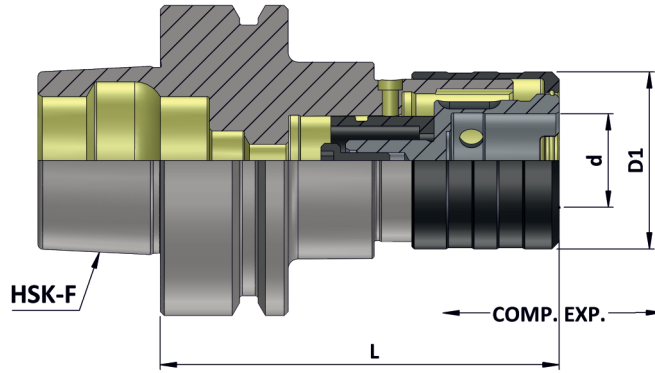

HSK-F (DIN 69893-6) (KWFLK)

Item Name	Item Code	HSK-F	Capacity	Suitable Adaptor	Comp.	Exp.	d	D1	L
HSK-63F KWFLK1 81	K10260169490127	63	M3-M12	KWES1B	7.5	7.5	19	36	81
HSK-63F KWFLK2 119	K10260170489127	63	M8-M20	KWES2B	12.5	12.5	31	53	119
HSK-63F KWFLK3 176	K10260171301127	63	M14-M33	KWES3B	20	20	48	78	176

Accessories:

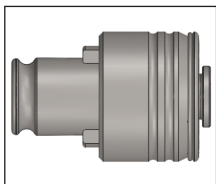

Tap Adaptor KWES..B & KWESK..B
 Ref. Page No. 260-279

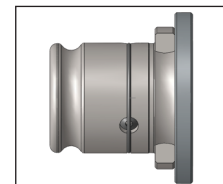
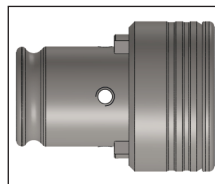

Tap Adaptor
 Reduction Socket KWRE
 Ref. Page No. 280

Note: • All Dimensions are in mm
 • For Tap Shank Dimension & Recommended Torque Values Ref. Page No. 281-284